

DISPLAY DE LED
Datasheet

TR1X-A22080VM-MCZ

Features:

- Low power consumption
- High intensity and solid state reliability
- Continuous and uniform segment
- Industrial standard size, IC compatible

Description:

- Digit height 20.32mm (0.8 inch), Single digit alphanumeric display
- Emitting color: Red, AlGaInP
- Gray face, White diffused epoxy
- Common anode

Absolute Maximum Ratings At Ta=25°C:

Parameter	Max	Unit
Reverse Voltage Per Dice	5	V
Forward Current	25	mA
Operating Temperature	-40 to + 85	°C
Storage Temperature	-40 to + 85	°C
Soldering Temperature	260 ± 5 (less than 5 sec.)	°C
Power Consumption Per Dice	60	mW

Electrical/Optical Characteristics At Ta=25°C:

Parameter	Symbol	Min.	Typ.	Max.	Unit	Condition
Luminous Intensity Per Segment	Iv	—	15	—	mcd	IF=10mA
Dominant Wavelength	λd	—	633	—	nm	IF=20mA
Spectrum Radiation Bandwidth	Δλ	—	20	—	nm	IF=20mA
Forward Voltage Per Segment	Vf	—	2.0	—	V	IF=20mA
Reverse Current Per Segment	Ir	—	—	10	μ A	VR =7V

Package Dimensions:

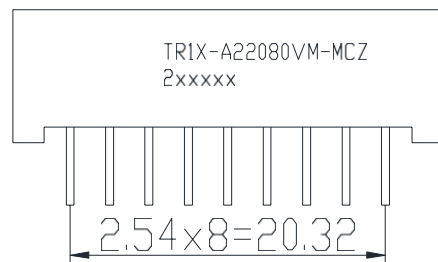
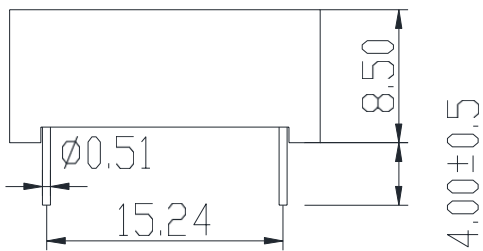
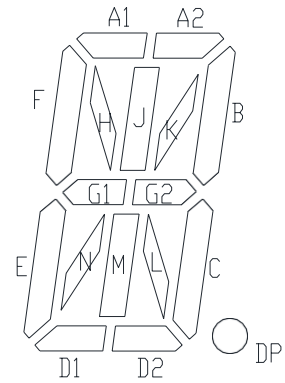
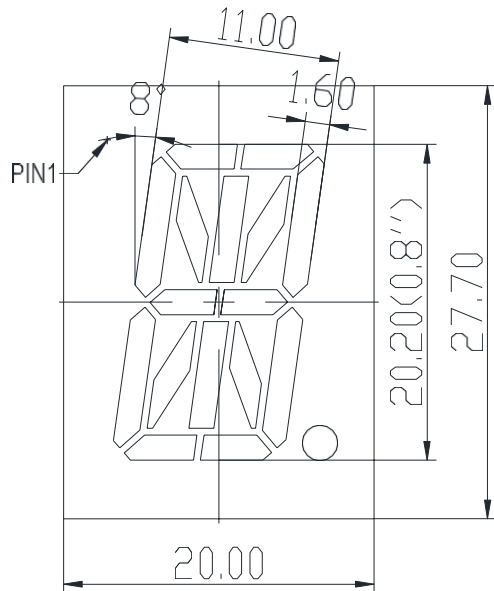

Notes:

- All dimensions are in millimeters(inches)
- Tolerance is 0.25mm(0.01") unless otherwise noted
- Above specifications may be changed without notice

Internal Circuit Diagram:

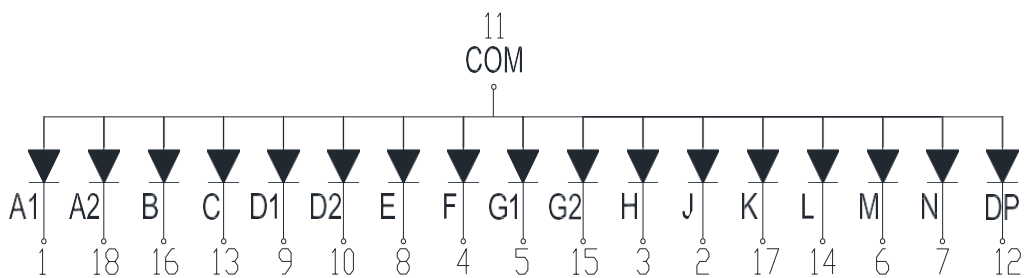

Typical Electro-Optical Characteristics Curves:

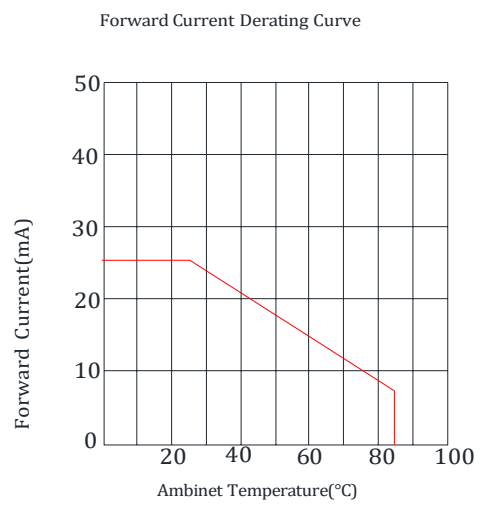
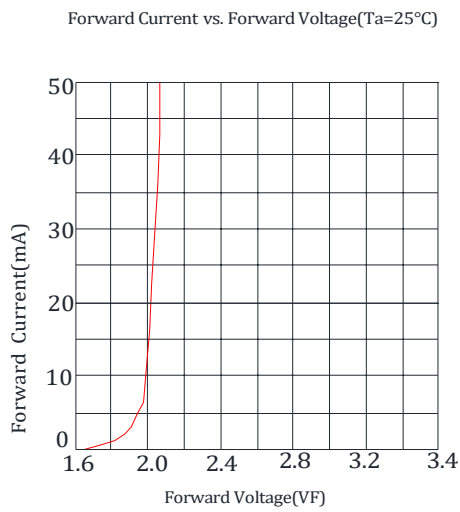
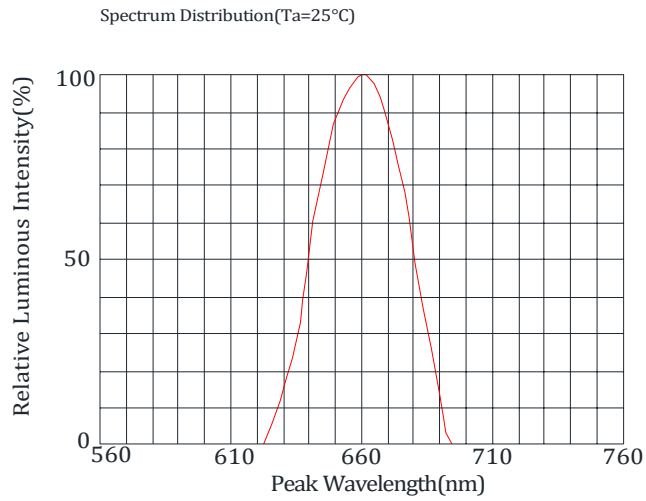

Packing:

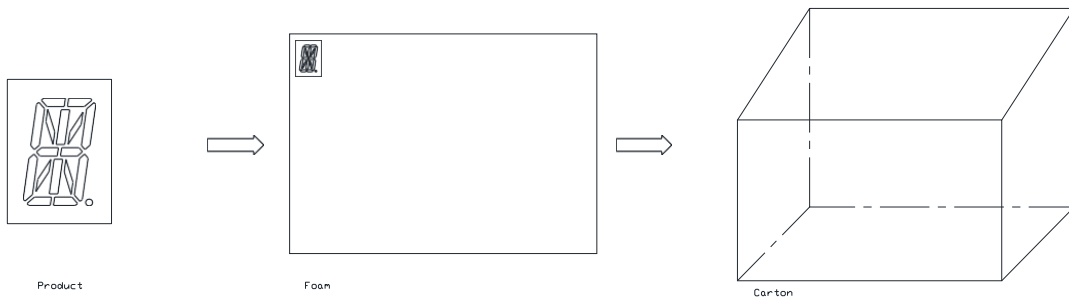

Reliability test:

Test Item	Standard	Test Condition	Note	Number of damaged
Room Temp. DC operating life	Lowering of brightness within 30%	25°C, If:20-25mA	1000hrs	0/100
Temperature cycle	Lowering of brightness within 30%, no damage	-20°C →25°C →80°C →25°C 30mins,5mins,30mins,5mins	10 cycles	0/100
Humidity Test	No damage	40±2°C, 90-95%RH	96 hrs	0/100
High Temp. storage	lowering brightness within 30%, no damage	100±2°C, non operated,	1000hrs	0/100
Low Temp. storage	lowering of brightness within 20%, no damage	-35 ± 5°C,non operated	1000hrs	0/100
Soldering Heat Endurance	No damage	260±10°C	10±1s	0/100
Solder ability	More than 90% covered by new solder	235±5°C	3±0.5s	0/100
Operating at High Temperature	lowering of brightness within 30%, no damage	85°C, all segments shall be operated	1000hrs	0/100
Operating at Low Temperature	lowering of brightness within 30%, no damage	-40°C, all segments shall be operated	1000hrs	0/100
Bending Strength	No damage	4x90°, with 0.5kg load	1 time	0/20
Tensile strength	No damage	1kg loaded	10±1sec	0/20