

SPECIFICATIONS FOR LIQUID CRYSTAL DISPLAY

MGD4002A-FL-YBS-02

DATE: 2009-12-11

DOC VER: 1.0

1.0 MECHANICAL SPECS

1. Overall Module Size	182.0mm(W) x 33.5mm(H) x max 13.5mm(LED Backlight)
2. Dot Size	0.60mm(W) x 0.65mm(H)
3. Dot Pitch	0.65mm(W) x 0.70mm(H)
4. Duty	1/16
5. Controller IC	ST7066U or Equivalent
6. LC Fluid Options	STN
7. Polarizer Options	Positive Yellow-Green and Transflective
8. Viewing Angle	6:00 o'clock
9. Backlight Options	LED(Yellow-Green)
10. Temperature Range Options	Standard temp.:(Operating:0°C ~ 50°C; Storage:-20°C ~ 70°C)

2.0 ABSOLUTE MAXIMUM RATINGS

Item	Symbol	Min	Typ	Max	Unit
Operating temperature (Standard)	Top	0	-	50	°C
Storage temperature (Standard)	Tst	-10	-	60	°C
Operating temperature (Wide temperature)	Top	-20	-	70	°C
Storage temperature (Wide temperature)	Tst	-30	-	80	°C
Input voltage	Vin	Vss		Vdd	V
Supply voltage for logic	Vdd- Vss	2.7	-	5.5	V
Supply voltage for LCD drive	Vdd- Vo	3.0	4.5	6.5	V

P/N:MGD4002A-FL-YBS-02	11/12/2009	VER: 1.0
-------------------------------	-------------------	-----------------

3.0 ELECTRICAL CHARACTERISTICS

Item	Symbol	Condition	Min	Typ	Max	Unit
Power Supply Voltage	Vdd	fosc=270kHz	4.5	5.0	5.5	V
Power Supply Current	Idd	Vdd=5.0V, fosc=270kHz	-	1.5	3.0	mA
Recommended LC Driving Voltage (Standard Temp)	Vdd - Vo	0°C	-	4.8	5.4	V
		25°C	4.2	4.5	-	
		50°C	3.9	4.3	-	
Recommended LC Driving Voltage (Wide Temp)	Vdd -Vo	-20°C	-	6.4	7.2	V
		0°C	-	4.8	-	
		50°C	-	4.2	-	
		70°C	3.5	4.0	-	
BackLight Power Supply Voltage	Vf	R=0Ω	-	5.0	5.5	V
BackLight Power Supply Current	If	R=0Ω	-	220	-	mA

4.0 OPTICAL CHARACTERISTICS (Ta=25°C, Vdd= 5.0V±0.25V, STN LC fluid)

Item	Symbol	Condition	Min	Typ	Max	Unit
Viewing angle (horizontal)	θ	Cr ≥ 2.0	-60	-	35	deg
Viewing angle (vertical)	φ	Cr ≥ 2.0	-40	-	40	deg
Contrast Ratio	Cr	φ=0°, θ=0°	-	6	-	
Response time (rise)	Tr	φ=0°, θ=0°	-	150	250	ms
Response time (fall)	Tf	φ=0°, θ=0°	-	150	250	ms

P/N:MGD4002A-FL-YBS-02	11/12/2009	VER: 1.0
-------------------------------	-------------------	-----------------

5.0 BLOCK DIAGRAM

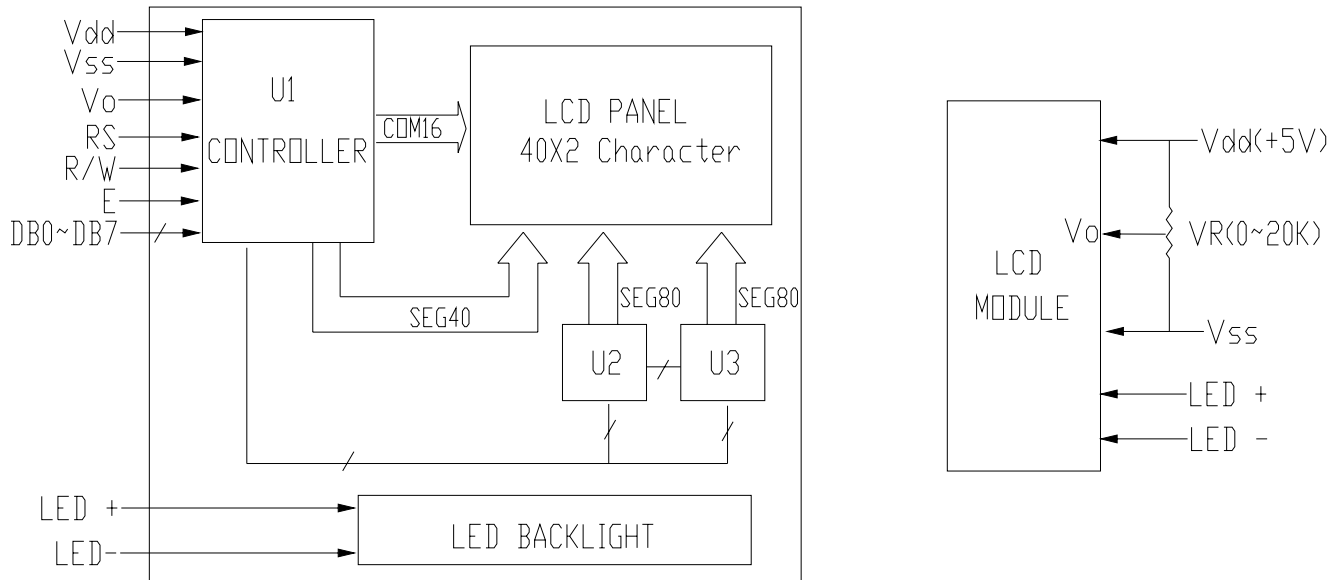

P/N:MGD4002A-FL-YBS-02	11/12/2009	VER: 1.0
------------------------	------------	----------

6.0 PIN ASSIGNMENT

Pin No.	Symbol	Function
1	Vss	Ground
2	Vdd	+5V
3	Vo	LCD contrast adjust
4	RS	Register select
5	R/W	Read / write
6	E	Enable
7	DB0	Data bit 0
8	DB1	Data bit 1
9	DB2	Data bit 2
10	DB3	Data bit 3
11	DB4	Data bit 4
12	DB5	Data bit 5
13	DB6	Data bit 6
14	DB7	Data bit 7
15	LED+	Power Supply for BL+
16	LED-	Power Supply for BL-

7.0 POWER SUPPLY

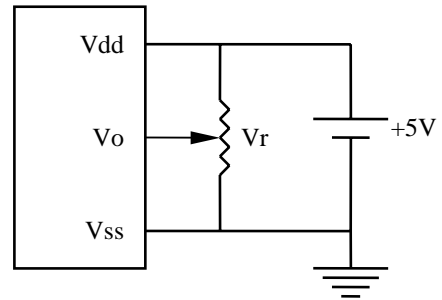

STANDARD TEMP RANGE

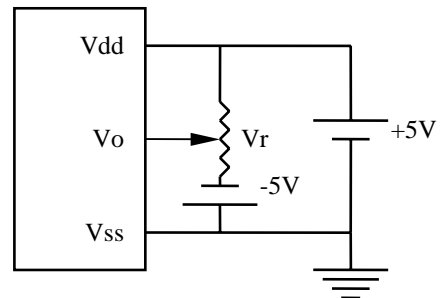

WIDE TEMP RANGE

$V_r = 10K\Omega \sim 20K\Omega$

8.0 TIMING CHARACTERISTICS

Item	Symbol	Test Condition	Min.	Typ.	Max.	Unit
Enable cycle time	t_c	Fig. a, Fig. b	500	-	-	ns
Enable pulse width	t_w	Fig. a, Fig. b	220	-	-	ns
Enable rise/fall time	t_r, t_f	Fig. a, Fig. b	-	-	25	ns
RS, R/W set up time	t_{su}	Fig. a, Fig. b	40	-	-	ns
RS, R/W hold time	t_h	Fig. a, Fig. b	10	-	-	ns
Data delay time	t_d	Fig. b	-	-	120	ns
Data set up time	t_{dsu}	Fig. a	60	-	-	ns
Data hold time	t_{dh}	Fig. a, Fig. b	20	-	-	ns

P/N:MGD4002A-FL-YBS-02	11/12/2009	VER: 1.0
------------------------	------------	----------

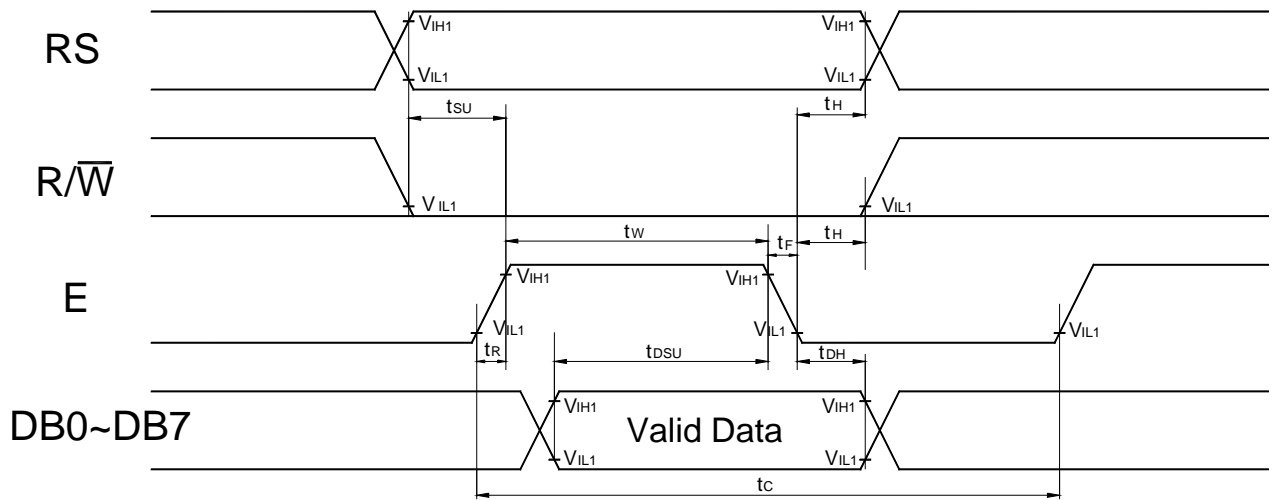

Fig. a Interface timing (data write)

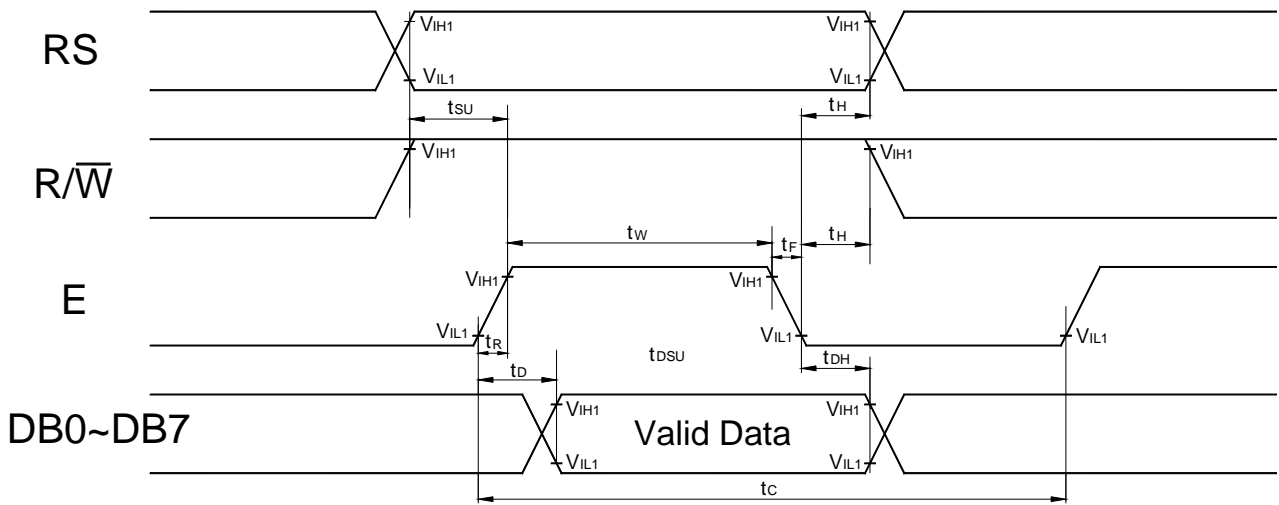
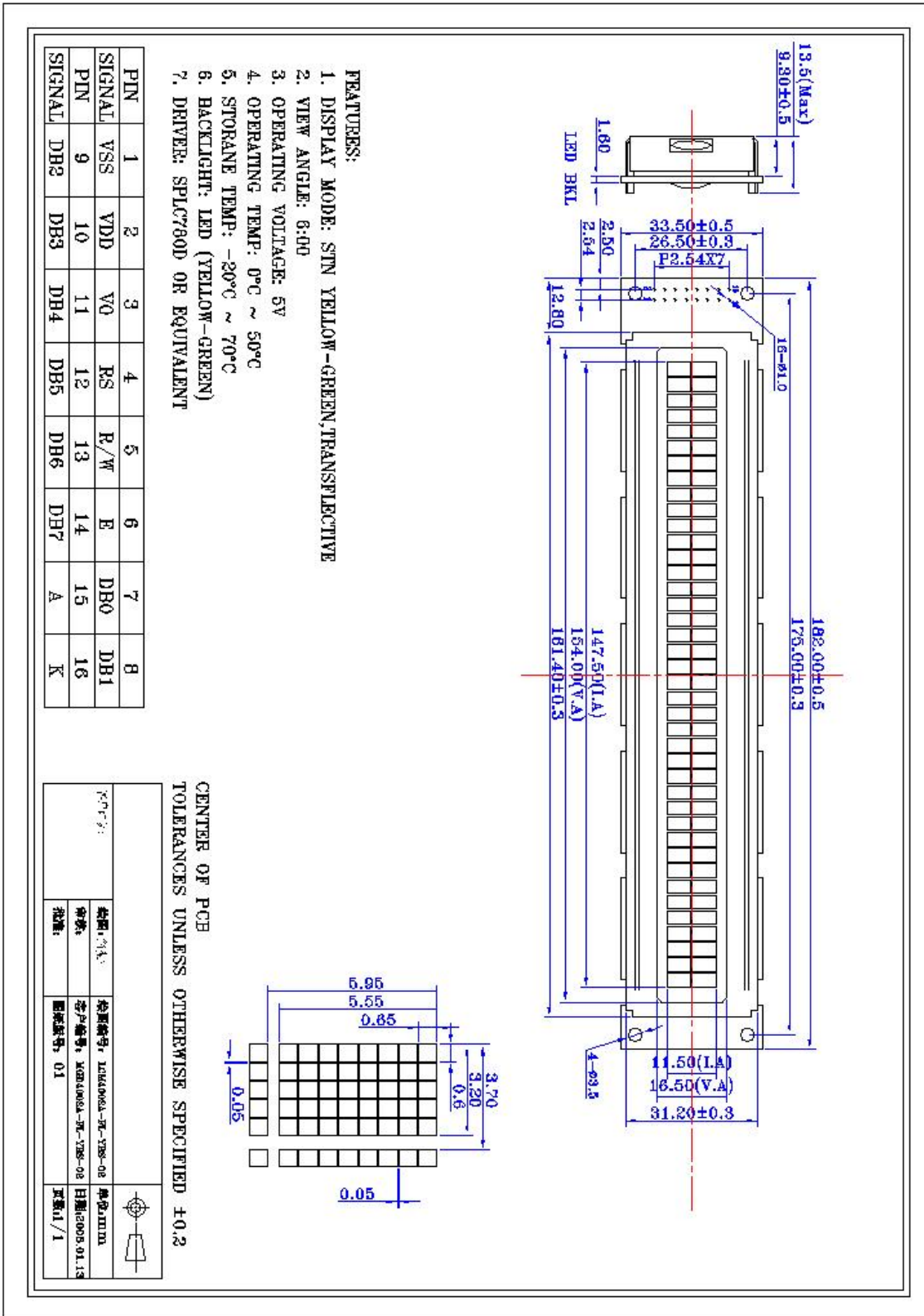

Fig. b Interface timing (data read)

P/N:MGD4002A-FL-YBS-02	11/12/2009	VER: 1.0
------------------------	------------	----------

9.0 MECHANICAL DIAGRAM



10.0 RELIABILITY TEST

Storage Condition	Content	Evaluations and Assessment*			
		Current Consumption	Oozing	Contrast	Other Appearances
Operation at high temperature and humidity	40°C,90% RH,240hrs	Twice initial value or less	none	More than 80% of initial value	No abnormality
High temperature storage	60°C, 240hrs	Twice initial value or less	none	More than 80% of initial value	No abnormality
Low temperature storage	-20°C, 240hrs	Twice initial value or less		More than 80% of initial value	No abnormality

*Evaluations and assessment to be made two hours after returning to room temperature (25°C±5°C).

*The LCDs subjected to the test must not have dew condensation.

11.0 DISPLAY INSTRUCTION TABLE

COMMAND	R S	R/ W	DB 7	DB 6	DB 5	DB 4	DB 3	DB 2	DB 1	DB 0	DESCRIPTION	Executing time fosc=250khz
Clear Display	0	0	0	0	0	0	0	0	0	1	Clears Display & Returns to Address 0.	1.64ms
Cursor at Home	0	0	0	0	0	0	0	0	1	x	Returns Cursor to Address 0. Also returns the display being shifted to the original position. DDRAM contents remain unchanged.	1.64ms
Entry Mode Set	0	0	0	0	0	0	0	1	I/D	S	I/D: Set Cursor Moving Direction I/D=1: Increment I/D=0: Decrement S: Specify Shift of Display S=1: The display is shifted S=0: The display is not shifted	40µs
Display ON/OFF Control	0	0	0	0	0	0	1	D	C	B	Display D=1: Display on D=0: Display off Cursor C=1: Cursor on C=0: Cursor off Brink B=1: Brink on B=0: Brink off	40µs
Cursor / Display Shift	0	0	0	0	0	1	S/C	R/L	x	x	Moves cursor or shifts the display w/o changing DD RAM contents S/C=0: Cursor Shift (RAM unchanged) S/C=1: Display Shift (RAM unchanged) R/L=1: Shift to the Right R/L=0: Shift to the Left	40µs
Function Set	0	0	0	0	1	DL	N	F	x	x	Sets data bus length (DL), # of display lines (N), and character fonts (F). DL=1: 8 bits F=0: 5x7 dots DL=0: 4 bits F=1: 5x10 dots N=0: 1 line display N=1: 2 lines display	40µs
Set CG RAM Address	0	0	0	1	Character Generator (CG) RAM Address					Sets CG RAM address. CG RAM data is sent and received after this instruction.		40µs
Set DD RAM Address	0	0	1	Display Data (DD) RAM Address / Cursor Address					Sets DD RAM address. DD Ram data is sent and received after this instruction.		40µs	
Busy Flag / Address Read	0	1	B F	Address counter used for both DD & CG RAM address					Reads Busy Flag (BF) and address counter contents.		40µs	
Write Data	1	0	Write Data								Writes data into DDRAM or CGRAM.	46µs
Read Data	1	1	Read Data								Reads data from DDRAM or CGRAM.	46µs

X: Don't Care

P/N:MGD4002A-FL-YBS-02	11/12/2009	VER: 1.0
-------------------------------	-------------------	-----------------

12.0 STANDARD CHARACTER PATTERNS

Lower 4 Bits \ Upper 4 Bits	0000	0001	0010	0011	0100	0101	0110	0111	1000	1001	1010	1011	1100	1101	1110	1111
xxxx0000	CG RAM (1)			0	@	P	`	P				-	夕	ミ	α	P
xxxx0001	(2)		!	1	A	Q	a	q			。	ア	チ	△	≡	q
xxxx0010	(3)		"	2	B	R	b	r			「	イ	ツ	×	β	θ
xxxx0011	(4)		#	3	C	S	c	s			」	ウ	テ	ε	ε	∞
xxxx0100	(5)		\$	4	D	T	d	t			、	エ	ト	†	μ	Ω
xxxx0101	(6)		%	5	E	U	e	u			・	オ	ナ	∟	ε	ü
xxxx0110	(7)		&	6	F	V	f	v			ヲ	カ	ニ	ヨ	ρ	Σ
xxxx0111	(8)		'	7	G	W	g	w			ア	キ	ヌ	ウ	g	π
xxxx1000	(1)		<	8	H	X	h	x			イ	ク	ネ	リ	∫	∞
xxxx1001	(2)		>	9	I	Y	i	y			ウ	ケ	ル	ル	'	y
xxxx1010	(3)		*	:	J	Z	j	z			エ	コ	ン	レ	j	≠
xxxx1011	(4)		+	;	K	[k	[オ	サ	ヒ	○	×	≠
xxxx1100	(5)		,	<	L	¥	l	l			カ	シ	フ	ワ	φ	≠
xxxx1101	(6)		-	=	M]	m]			ユ	ズ	ハ	ン	≠	÷
xxxx1110	(7)		.	>	N	^	n	→			ヨ	セ	ホ	°	≠	
xxxx1111	(8)		/	?	O	_	o	†			ッ	リ	マ	°	ö	■

Note: The character generator RAM is the RAM with which the user can rewrite character patterns by program.

P/N:MGD4002A-FL-YBS-02	11/12/2009	VER: 1.0
------------------------	------------	----------