

LED Datasheet

TR-5MMRGB30-WC

Benefits:

- High intensity
- Low power consumption
- Solid state reliability
- Optimal optical and mechanical design

Features:

- 5.0*8.7mm lamp LED
- Lens color: Water clear
- Emitting color: RGB
- Viewing angle: 30°

Package Dimensions:

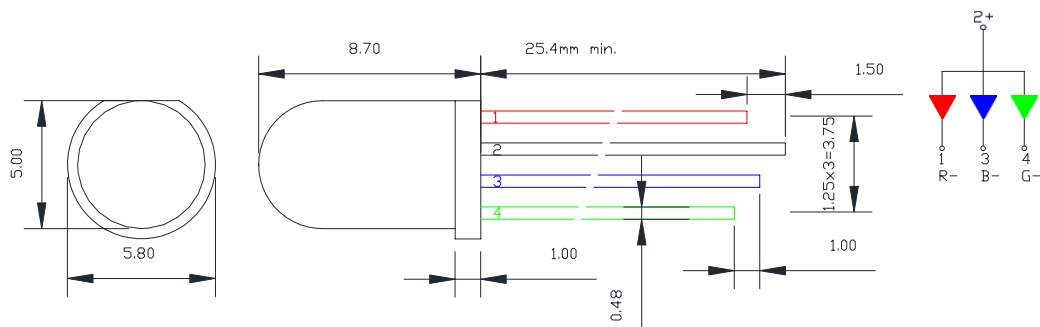

Notes:

- All dimensions are in millimeters.
- Tolerance is ± 0.25 mm unless otherwise noted.
- Specifications are subject to change without notice.

Absolute Maximum Ratings At Ta=25°C

Parameter	Symbol	Ratings	Unit
Power Dissipation	Pd	R:60, G:100,B:100	mW
Peak Forward Current (1/10 Duty Cycle, 0.1ms Pulse Width)	Ifp	100	mA
Forward Current	If	30	mA
Reverse Voltage	Vr	5	V
Soldering Temperature Range	Tsol	260°C within 3s	
Operating Temperature Range	Topr	-30°C to + 85°C	
Storage Temperature Range	Tstg	-40°C to + 85°C	

Electrical/Optical Characteristics At Ta=25°C

Parameter	Symbol	Min.	Typ.	Max.	Unit	Condition
Luminous Intensity	I _v	R	3000	—	5000	mcd I _F =20mA
		G	6000	—	8000	
		B	2500	—	3500	
Viewing Angle	2θ _{1/2}	—	30	—	Deg.	I _F =20mA
Dominant Wavelength	λ _d	R	620	—	630	nm I _F =20mA
		G	515	—	525	
		B	460	—	475	
Forward Voltage	V _F	R	1.8	2.0	2.6	V I _F =20mA
		G	2.8	3.0	3.6	
		B	2.8	3.0	3.6	
Reverse Current	I _R	—	—	10	μ A	V _R =5V

Electrical/Optical Characteristics At Ta=25°C

Red color:

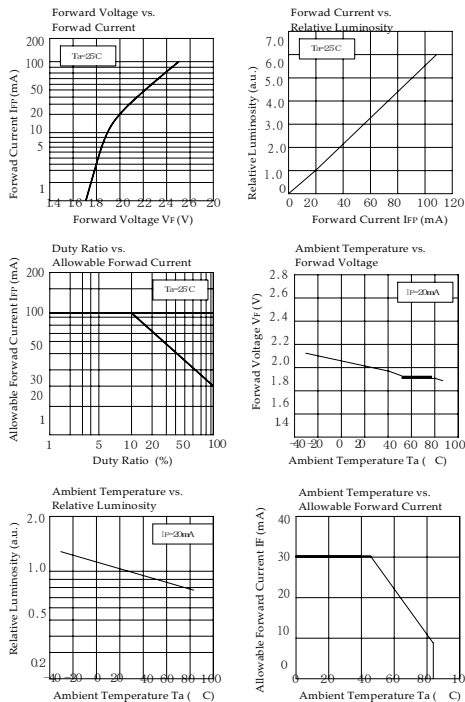

Blue color:

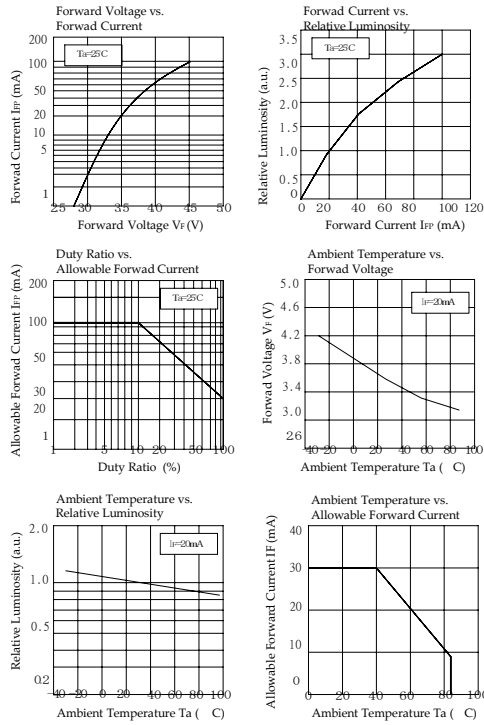

Green color:

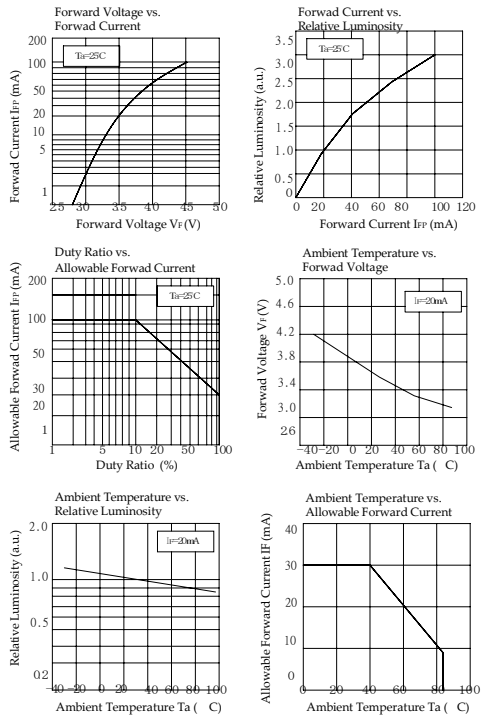

Reliability Items and Conditions:

Test Item	Test Conditions	Note	Sample Size	Ac/Re
Solderability	235°C ±5°C, 3 ±0.5 s	>95% Tinned	22pcs	0/1
Resistance to Soldering Heat	260°C ±5°C	10Sec.	22pcs	0/1
Thermal Shock	-10°C ~ 100°C 5Min. 10Sec. 5Min.	100Cycles	22pcs	0/1
Temperature Cycle	-40°C 25°C 100°C 30Min. 5Min. 30Min.	100Cycles	22 pcs	0/1
Hi-Temp. Storage	100°C	1000Hrs	22 pcs	0/1
Low-Temp. Storage	-40°C	1000Hrs	22 pcs	0/1
Hi-Temperature/ Hi-Humidity Test	85°C/85%RH	1000Hrs	22 pcs	0/1
Operating Life	TA=25°C, IF =20mA	1000Hrs	22 pcs	0/1
Bending Test	4x90°, with 0.5kg load	No Damage	22 pcs	0/1
Storage/shelf life	≤30°C, ≤70%RH	>1 year	22 pcs	0/1
Manufacturing/delivery date information	Year/month/date on bag			

Precautions for use:

1. Lead Forming & Assembly

- Any lead forming or bending must be done before soldering, at normal temperature.
- When forming leads, there must be a minimum of 3mm clearance between the base of the LED lens and the lead bend.
- Do not use the base of the lead frame as a fulcrum during lead forming.
- Avoid bending the leads at the same point more than once.
- During assembly onto PCB, the lead pitch of the LED must match the pitch of the mounting holes on the PCB during component placement.

2.Cleaning:

- Isopropyl alcohol or deionized water are recommended solvents for cleaning. When using other solvents, it should be confirmed beforehand whether the solvents will dissolve the resin or not.

3.Storage

- The storage ambient for the LEDs should not exceed 30°C temperature or 70% relative humidity.
- It is recommended that LEDs out of their original packaging are used within three months. For extended storage out of their original packaging, it is recommended that the LEDs be stored in a sealed container with appropriate desiccant or in desiccators with nitrogen ambient.

4.ESD (Electrostatic Discharge)

Static Electricity or power surge will damage the LED.

The following procedures may decrease the possibility of ESD damage.

- All production machinery and test instruments must be electrically grounded.
- Use a conductive wrist band or anti-electrostatic glove when handling these LEDs.
- Maintain a humidity level of 50% or higher in production areas.
- Use anti-static packaging for transport and storage.

Wave soldering:

The minimum distance between LED lens and tin is 2mm.

