

# WP3084ADAM

## User's Manual

### Version 1.42

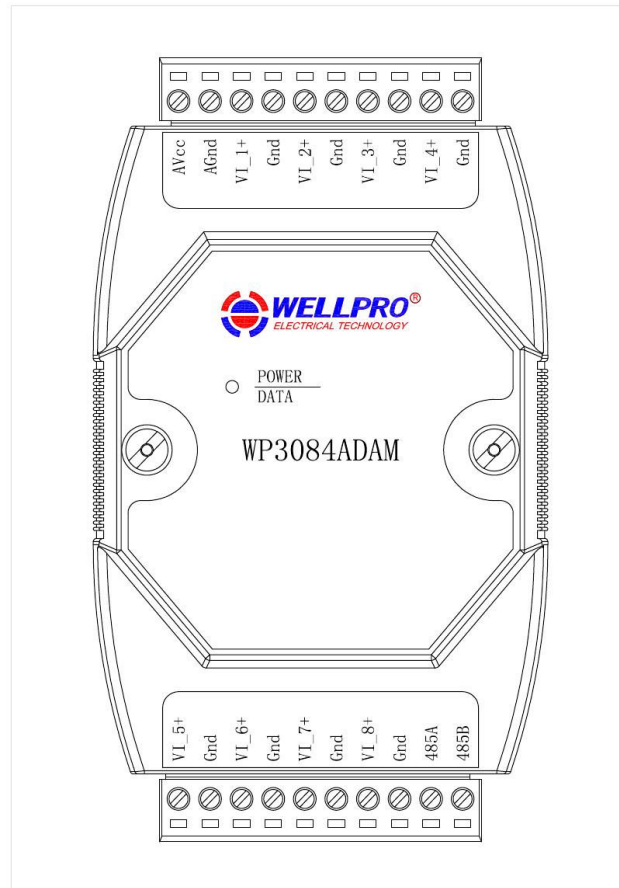

Shanghai Wellpro Electrical Technology Co., Ltd.  
[www.shwellpro.com](http://www.shwellpro.com)

### 1、Product description

- 8ch single-ended analog type:DC 0-10V,using 12bit AD chip
- Using RS485 MODBUS RTU communication standard. It can be netted with configuration software, PLC and industry touch pad
- Communication status LED
- Communication circuit designed for lightening protection and interference immunity
- Could be used for signal collection and control of Industrial field apparatus
- 3 Year's quality assurance for normal use

### 2、Specification

- Analog iutput 8ch single-ended
- Analog iutput range DC 0-10V
- Analog iutput accuracy  $\pm 0.02V$
- Working Temperature  $-20\sim 70^{\circ}C$
- External power supply DC 9V $\sim$ 30V/2W
- Isolation protect 1500VDC
- Installation method Standard DIN slide rail or screw
- Dimension 125 $\times$ 73 $\times$ 35mm

### 3、Interface definition

AVcc	External PSU positive terminal input
AGnd	External PSU negative terminal input
VI 1+	positive terminal of the first analog input
Gnd	signal ground,negative terminal of the first analog input
VI 2+	positive terminal of the second analog input
Gnd	signal ground,negative terminal of the second analog input
VI 3+	positive terminal of the third analog input
Gnd	signal ground,negative terminal of the third analog input
VI 4+	positive terminal of the fourth analog input
Gnd	signal ground,negative terminal of the fourth analog input
VI 5+	positive terminal of the fifth analog input
Gnd	signal ground,negative terminal of the fifth analog input
VI 6+	positive terminal of the sixth analog input
Gnd	signal ground,negative terminal of the sixth analog input
VI 7+	positive terminal of the seventh analog input
Gnd	signal ground,negative terminal of the seventh analog input
VI 8+	positive terminal of the eighth analog input
Gnd	signal ground,negative terminal of the eighth analog input
485A	RS485 signal A+
485B	RS485 signal B-

### 4、Analog application diagram

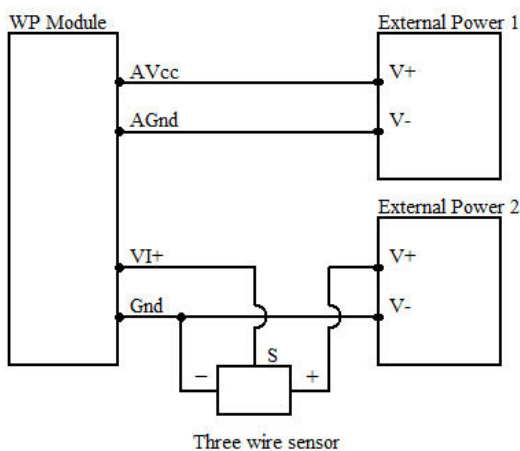

5、Communication Instruction

5.1、Communication parameter (default setting): 9600, N, 8, 1

Parameter	Description
9600	baud rate
N(no check)	check bit
8	data bit
1	stop bit

5.2、Command for collecting the input signal of analog quantity:

Send:01 03 00 00 00 08 44 0C (example/hexadecimal)

data	byte	data description	remark
01	1	module address	address range:01-FE
03	1	function code	03-read register
0000	2	register address (4x mode)	0000-analog input address of first register
0008	2	reading length	0008-read 8 registers
440C	2	CRC check code	CRC check code for all data

Receive: 01 03 10 05 AF 00 00 00 00 00 00 00 00 00 00 00 00 C8 76 (example/hexadecimal)

data	byte	data description	remark
01	1	module address	address range:01-FE
03	1	function code	03-read register
10	1	byte numbers	10-read 16 bytes
05AF	16	read data	05AF-read data from the first analog input
0000			0000-read data from the second analog input
0000			0000-read data from the third analog input
0000			0000-read data from the fourth analog input
0000			0000-read data from the fifth analog input
0000			0000-read data from the sixth analog input
0000			0000-read data from the seventh analog input
0000			0000-read data from the eighth analog input
C876	2	CRC check code	CRC check code for all data

The recieved command means the data of the first analog input is “05AF”,and it is equal to 1455 in decimal,then substitute into the fomula:  $V=(DATA*100)/4095=(1455*10)/4095\approx 3.55V$ . The other channel is 0V.

5.3、command for module address setting:

Send: 00 06 00 64 00 01 08 04 (example/hexadecimal)

date	byte	data description	remark
00	1	module address	00-group sending
06	1	function code	06-write single register
0064	2	register address (4x mode)	0064-modify module address
0001	2	data writing	set new address for module, range 0001-00FE
0804	2	CRC check code	CRC check code for all data

Receive: 00 06 00 64 00 01 08 04 (example/hexadecimal)

This command means to send a code to a module, set the module address as 01, this setting could be saved when power off; default address of module is 01,each module address could be assigned separately when using multiple modules for network.Attentions is required that only one module could be used in 485 network when using multiple address sending, otherwise all the modules will share the same address in 485 network. When module receives correct command, it will make corresponding actions and send response back to the master. This is successful communication.

5.4、Command for communication parameter setting:

Send: 01 06 00 65 00 02 18 14 (example/hexadecimal)

data	byte	data description	remark
01	1	module address	address range:01-FE
06	1	function code	06-write single register
0065	2	register address (4x mode)	0065-modify communication parameter
0002	2	data writing	0001-set communication parameter 4800,N(no check) ,8,1
			0002-set communication parameter 9600,N(no check) ,8,1
			0003-set communication parameter 19200,N(no

			check) ,8,1 0004-set communication parameter 38400,N(no check) ,8,1 0005-set communication parameter 4800,E(even check) ,8,1 0006-set communication parameter 9600,E(even check) ,8,1 0007-set communication parameter 19200,E(even check) ,8,1 0008-set communication parameter 38400,E(even check) ,8,1
1814	2	CRC check code	CRC check code for all data

Receive: 01 06 00 65 00 02 18 14 (example/hexadecimal)

This command means to send a code to the module and set the communication parameter as “9600, N (No check), 8, 1”. This setting could be saved when power off. The default communication parameter is “9600, N (no check), 8, 1”. Attention is required, when electing the correct communication parameter in communication setting and restarting the communication terminal, setting will be done. Normally, the lower of baud rate, the lower of the transaction speed but the higher of transaction stability. The opposite is also true. When module receives correct command, corresponding action will be taken and response will be sent back to the master. This is successful communication.

### 6、Indicator LED description

- When module powered on, Led is green.
- When module is under communication, LED is twinkling.
- when module receive correct command, LED is green.
- when module receive incorrect command or command for other modules, LED is red.

### 7、PC debugging instruction

This module provides software for parameter setting and function test. Please follow the steps below:

- Connect the module and computer using RS485 converter.
- Connect 12V or 24V power with module and power on. **To avoid any unnecessary damage, please make sure the power positive & negative terminals are correctly connected before power on.**
- Open the software, select the correct module number, you will see the window of function test or parameter setting.
- Set correct parameter, open communication interface.
- Select corresponding setting, collection and control items.

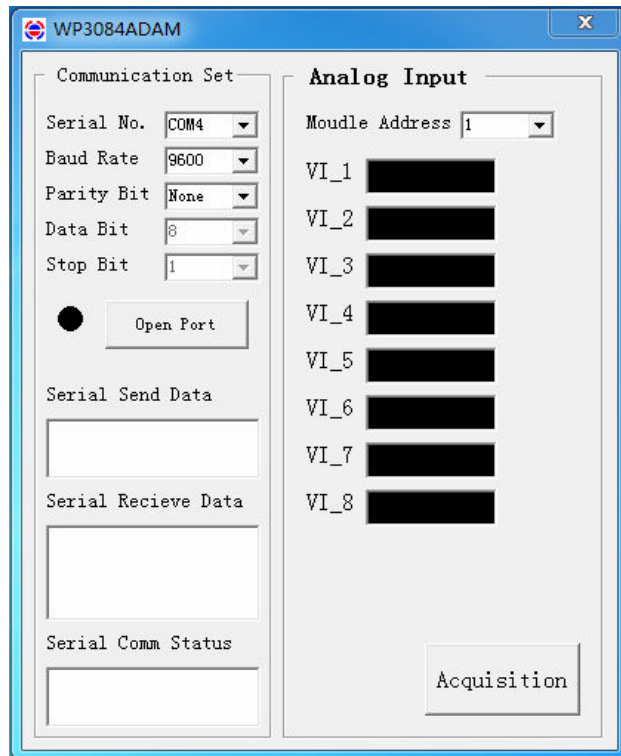

8、RS485 network diagram

